

# PRIDE®

MOBILITY

LIVE YOUR BEST®

[www.pridemobility.com](http://www.pridemobility.com)

**Jazzy**  
carbon 27



OWNER'S MANUAL

Rev.A-25-10200089

**PRIDE**  
MOBILITY  
LIVE YOUR BEST®  
[www.pridemobility.com](http://www.pridemobility.com)



401 York Ave Duryea ,PA 18642

**CONTENTS**

**1.INTRODUCTION** ..... 1

**2.CONTACT INFORMATION** ..... 3

**3.PRODUCT DESCRIPTION** ..... 3

3.1 Environment ..... 4

3.2 Intended User Group ..... 4

3.3 Intended Use ..... 4

3.4 Indications ..... 4

3.5 Product Overview ..... 4

**4.SAFETY** ..... 5

4.1 Risk Assessment ..... 5

4.2 Contraindications ..... 5

4.3 Powerchair Loading ..... 5

4.4 Training ..... 6

4.5 General Warnings ..... 6

**5.TRANSPORT & STORAGE** ..... 9

**6.SYMBOL DEFINITION** ..... 11

**7.PARTS IDENTIFICATION** ..... 13

**8.CHARGING & PREPARING FOR USE** ..... 16

8.1 Installation ..... 16

8.2 Battery Charging ..... 16

8.3 Assembling ..... 17

8.4 Checking Before Use ..... 18

**9.OPERATION OF THE POWERCHAIR** ..... 21

9.1 Driving the Powerchair ..... 21

9.2 Steps, curbs & Fixed Obstacles ..... 22

9.3 Engineering menu operation instructions ..... 23

9.4 Wheelchair Lock/Unlock Function ..... 24

9.5 Inclines ..... 25

9.6 Antitipper instruction ..... 25

9.7 Precautions for safe use ..... 25

9.8 After Use Instructions ..... 26

**10.CLEANING** ..... 27

**11.MAINTENANCE & SERVICING** ..... 28

11.1 General Guidelines ..... 28

11.2 Fault Detection ..... 30

**12.DISPOSAL OF PARTS** ..... 32

**13.ELECTROMAGNETIC COMPATIBILITY (EMC)** ..... 33

**14.SPECIFICATION** ..... 34

**15.MAINTENANCE SCHEDULE** ..... 35

**16.OPENING AND CHECKING** ..... 36

**17.WARRANTY** ..... 37

# 1. INTRODUCTION

Thank you for purchasing this product. These instructions for use should be read carefully and understood before operating the powerchair. Improper use or unfamiliarity with the powerchair may result in harm, injury or traffic accidents. A repair maintenance schedule has also included at the back. Keep this manual with the powerchair, or in a safe place.

**1.1** Contact Pride Mobility Products, or check our website for the latest version of this document. Users with visual, reading or cognitive disabilities should seek advice from a professional care provider for an appropriate format. If this is not viable, users should contact your Pride Provider or Pride Mobility Products. If you have any questions concerning the operation or maintenance of the powerchair, contact your Pride Provider or Pride Mobility Products.

**1.2** Do not use your wheelchair until this entire manual and all relevant booklets have been read and understood!

If one of the user manuals was not included with your wheelchair, please contact your dealer immediately.

 **WARNING!**  
In this user manual highlight potential hazards that if disregarded could lead to injury or death.

 **CAUTION!**  
In this user manual highlight potential hazards that if disregarded could lead to equipment damage or failure.

**NOTE:**General user advice.

Not following these instructions may result in physical injury, damage to the product or damage to the environment!

Notice to the user and/or patient: Any serious incident that has occurred in relation to the device should be reported to the manufacturer and the competent authority of the Member State in which the user and/or patient is established.

This manual is composed from the product design and specifications at the time of publication. As designs change, some illustrations and pictures in the manual may not correspond to the powerchair that you purchased. We reserve the right to make design modifications.

## 2. CONTACT INFORMATION

For assistance in setting up, using, maintaining your powerchair, to report unexpected operation or for any service, warranty, sales or customer service information regarding this product, please contact your Pride Provider or Pride Mobility Products Ltd.

	<b>Zhejiang Innuovo Rehabilitation Devices Co.,Ltd.</b> 196 Industry Road, Hengdian Movie Zone,Dongyang,Zhejiang,CN Tel: +86057989327233 Email: jk@innuovo.com
	<b>Pride Mobility Products Corp.</b> 401 York Ave Duryea ,PA 18642

Any serious incident that has occurred in relation to the device should be reported to the manufacturer and the **FDA** or competent authority of your Member State. Please quote the product serial code on all correspondence, which can be found on the label on the inside of the frame.

For Service & Support outside the United Kingdom, please contact the local distribution company from where this equipment was purchased. Failure to do so may result in the product warranty becoming void.

## 3. PRODUCT DESCRIPTION

### 3.1 Environment

Jazzy Carbon 27 Powerchair can be used indoors and outdoors, but only in good weather. Jazzy Carbon 27 Powerchair can be used on flat, even path surfaces, however the user should avoid grass, gravel, gradients greater than 6° and motorised roads. Additional care should be taken to avoid inclement weather and wet surfaces.

### 3.2 Intended User Group

Jazzy Carbon 27 Powerchair is intended for a single user of weight up to 136kg. The intended user group for this device is any mobility restricted individual that requires assistance with transport. The patient / occupant is the only intended operator. Users must be both mentally and physically capable of operating the device with minimal risk of injury to themselves and others.

### 3.3 Intended Use

The intended use of the powerchair is to transport an end user with restricted mobility, as defined in section 3.2. The powerchair is intended to support a single occupant. A risk assessment must always be performed on the suitability of the user to the powerchair.

### REGARDING DEVICES FOR PRESCRIPTION USE

Our mobility products and their and components are available for sale either as retail ("over-the-counter" or with a prescription, When prescribed, the follow statement is applicable.



#### CAUTION!

Federal law restricts this device to sale by or on the order of a physician or other certified personnel licensed by the law of the State (US only) or region in which this personnel practices to use or order the use of the device.

### 3.4 Indications

To provide transport mobility to an end user with restricted mobility.

### 3.5 Product Overview

The Carbon fiber Jazzy Carbon 27 Powerchair has been designed to provide a comfortable and secure solution for users who have mobility restrictions. The product is a class A powerchair (under ISO 7176).

Jazzy Carbon 27 Powerchair is designed to be suitable for indoor use and outdoor use, in good weather. For specific guidance and warning with use, see section 8. This manual is composed from the product design and specifications at the time of publication. As designs change, some illustrations and pictures in the manual may not correspond to the powerchair that you purchased. We reserve the right to make design modifications.

## 4. SAFETY

### 4.1 Risk Assessment

Before using the powerchair, a risk assessment must be performed by a competent individual to ensure the safe use of the powerchair on a user-by-user basis. It is the responsibility of users and carers to determine that they are both mentally and physically capable of operating the powerchair with minimal risk of injury to themselves or others. The risk assessment should include, but not be limited to:

- Entrapment
- Falling out of the powerchair
- Small adults (and children)
- Individuals who lack capacity
- Users with visual, reading or cognitive disabilities
- Very active occupants
- Unauthorised people with access to the powerchair

### 4.2 Contraindications

- The end user exceeds maximum weight capacity indicated in section 4.3
- The end user has postural support needs that are not addressed by the Jazzy Carbon 27 Powerchair
- Inability to safely guide a power mobility device
- Other contraindications may be relevant which are specific to an individual and / or care environment.

### 4.3 Powerchair Loading

The maximum occupant mass of the Jazzy Carbon 27 Powerchair is: 136 kg. Maximum occupant mass is the sum of the user mass and the mass of any ancillary attachments or accessories. Exceeding the maximum occupant mass will void your warranty. This manufacturer or Pride Mobility Products. will not be held responsible for injury and / or damages resulting from failure to observe load capacities.



#### WARNING!

- The maximum load is for the powerchair to be occupied by one person only. Additional weight could damage components or destabilise the powerchair, potentially causing injury.
- The powerchair may only be used to transport one person at a time. It should not be used for climbing. The backrest is not designed to support an entire person's body weight, and the armrests are not designed to support other individuals sitting / leaning- risk of collapse, entrapment.
- The powerchair is not a toy. Children should not be allowed to play near or operate the powerchair, as they are at risk of harm.

### 4.4 Training

All individuals operating the Jazzy Carbon 27 Powerchair are to be suitably familiar with the functionality and limitations prior to use. It is the responsibility of the user to ensure they are suitably trained to use the powerchair and any associated parts safely and correctly. Every effort should be made to resolve deficiencies and should include consideration of retraining, falls prevention and equipment alterations and modifications.

If these instructions for use are not deemed sufficient and the need for training is required, please contact your Pride Provider or Pride Mobility Products. (see section 2) who can discuss training options with you.

### 4.5 General Warnings



#### WARNING!

- Do not use a damaged or badly worn powerchair- risk of harm.
- Check the functionality of the powerchair before every use. Ensure the joystick and control system is responsive and free from unintended movement. Check the current fastest speed setting is appropriate. (It is recommended to use a slower speed setting at the beginning of every use, gradually increasing the speed setting as appropriate.)
- Ensure your lap belt is secured before operating the powerchair.
- Exposure to inclement weather should always be avoided.
- Monitor weather forecasts before starting a journey, to reduce risks. If you find yourself caught in inclement weather, such as heavy rain or snow, whilst operating your powerchair, proceed to the closest shelter immediately.

**WARNING!**

- Completely dry your powerchair before operating, charging or storing it.
- Do not drive on grass, motorised roads or in muddy or icy conditions.
- Reduced speed and care should be taken when navigating obstacles.
- Do not attempt to navigate on slopes greater than 6°.
- If unintended movement of the powerchair occurs, release the joystick to automatically stop the powerchair. If this fails, cut off power to the powerchair.
- Under no circumstances should the powerchair be used as a seat in a motor vehicle
- The powerchair is designed for occupants who weigh less than 136 kg; overloading may put the user at risk of falling or entrapment.
- Do not touch any exposed contacts or connectors while using the product or while in contact with other individuals

**WARNING!**

- Misused electrical equipment can be hazardous
- Do not operate the powerchair whilst under the influence of alcohol or when excessively tired.
- Do not operate the powerchair at night near motorised roads or in situations without a clear line of sight.
- Only approved parts, specified for the Jazzy Carbon 27 Powerchair, should be used. Accessories that have not been approved or designed for use with the powerchair are not to be used - a hazard could be introduced due to product combination incompatibility. If in doubt, contact your Pride Provider or Pride Mobility Products.
- Modification of the Jazzy Carbon 27 Powerchair, its parts or features is not allowed without the permission of the manufacturer a hazard could be introduced. The powerchair is electrically operated, so should not be used in oxygen-rich environments, in the presence of flammable gases, sources of heat or naked flames - risk of explosion /fire. Damaged or worn upholstery increases the risk of fire hazard and should be replaced immediately. Individuals unable to drive the powerchair without assistance or supervision must not use the powerchair without such supervision. Unsupervised use of the powerchair must be avoided if there is any doubt about the ability of an individual to operate it safely.

**WARNING!**

- Do not step on the footrest whilst loading or unloading from the powerchair. Risk of instability.
- If children, adults with learning difficulties or pets pose a potential risk of tampering with the powerchair, its suitability for use is to be considered during the initial user / product risk assessment.
- Do not use the Jazzy Carbon 27 Powerchair while in freewheel (manual) mode. Always seek assistance if freewheel mode is used. Do not use the powerchair in freewheel mode when on any slope.
- Only use the approved battery charger supplied with the Jazzy Carbon 27 Powerchair to charge the Lithium (Lithium-ion) battery pack supplied with the Jazzy Carbon 27 Powerchair.
- Do not recommend users with heavy incontinence operate the powerchair without nursing care or an attendant.

## 5. TRANSPORT & STORAGE

Environmental conditions for transport and storage:

- Ambient temperature: **0°C to +40°C**
- Humidity: **<80%RH**

Follow these conditions when transporting or storing the powerchair:

- Store the powerchair fully folded, on a flat, level floor .
- Always fully charge, then remove the battery prior to long-term storage.
- The powerchair should be stored in clean and dry conditions. Cover to protect from fluid ingress, dirt, dust etc.
- Powerchairs should not be stored on their side, their backs, or stacked.When transporting powerchairs by vehicle, they should be securely stowed in the back of a van, truck, or boot of a car. Adjustable parts should be removed or properly secured during transport.Keep the instructions for use with the powerchair or in a safe place.

**Note:** This vehicle is suitable for land and air transport, but contact your carrier in advance to determine their specific requirements. The lithium battery pack may require special packaging and storage provisions in line with IATA or UN Guidelines. To remove the battery, press the release button and then pull forward on the handle.

- If your powerchair is stored for a prolonged period, flat spots may develop in the wheels, causing an uneven sensation when driving. This should work itself out over time.We suggest placing a sturdy platform under the frame to lift the wheels off the ground and take weight off the wheels during storage. If you notice flat spots after continued use, replace the powerchair wheels immediately.



### **WARNING!**

Improper storage of your powerchair may result in permanent damage to the frame and / or electronics.Do not sit in the powerchair while in a moving vehicle.

























### **CAUTION!**

Always lift your powerchair by the frame. Do not attempt to lift by any removable parts (e.g. seat or armrests).Infrequently charged batteries, or batteries stored without a full charge are susceptible to permanent damage, causing unreliable performance from your powerchair.Avoid placing the powerchair in direct sunlight -this could damage the electrical system and / or cause label fading. Clean the powerchair in line with section 10 prior to storage.

## 6. SYMBOL DEFINITION

The following symbols are found on the Powerchair:

Symbol	Description
	Warning - Beware of potential hazard
	Caution - Beware of potential product damage
	Refer to instructions for use - Mandatory (Failure to read may introduce a hazard)
	Medical Device
	Maximum occupant mass
	Use no hooks
	Refer to instructions for use - Mandatory Failure to read the instructions for use could introduce a hazard
	Serial Number
	Product Code
	Model Number
	Quantity

Symbol	Description
	Manufacturer
	Date of manufacture
	Importer
	Distributor
	Waste Electrical and Electronic Equipment
	Beware of trapping points
	Locked and in drive mode Place unit on level ground and stand to one side when changing from drive mode to freewheel mode or freewheel mode to drive mode Unlocked and in freewheel mode
	Class II Equipment
	Power Chair information label
	Manufactured in
	Unfold and fold

## 7. PARTS IDENTIFICATION

### 7.1 Electric wheelchair

This power wheelchair consists of the main part including the frontwheel, drive wheel, frame, controller, motor with mechanism, armrest, push handle, backrest, seat base, footrest, battery case and charger, the structure shown in Figure.

- A. Push handle
- B. Joystick
- C. Back rest
- D. Armrest
- E. Seat cushion
- F. Frame
- G. Front wheel
- H. Battery case
- I. Motor with mechanism
- J. Drive wheel



### 7.2 Controller

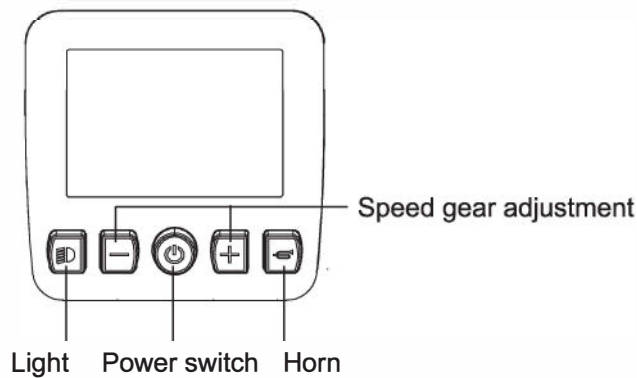

- **Power switch:** Turn the power wheelchair on/off.
- **Joystick:** The main function of the joystick is to control the speed and direction of the power wheelchair. When the joystick is released, it will automatically reset and brake. If the power wheelchair is operating abnormally, do not operate it.
- **Horn button:** The horn will sound when you press this button.
- **“+” button:** Increase speed.
- **“-” button:** Decrease speed.
- **Charging port (back of controller):** Used to charge the power wheelchair. This charging port should not be used as a power supply for any other electrical device. If other electrical devices are connected, the controller may be damaged or the EMC (Electromagnetic Compatibility) performance of the wheelchair may be affected.
- **Light button:** Press the button lightly, the front light of the controller lights up, press the button again to turn it off.

### 7.3 Battery

The Jazzy Carbon 27 Powerchair's batteries should be fully charged (approximately 8-12 hours before its initial use. This initial charge will allow the battery to perform at about 90% of its optimal performance. Following the initial use, it is recommended to perform another 8-12 hour charge to improve the battery's performance. After the first few uses and charges of the battery, it should be operating at optimal performance and will extend the lifespan of the battery. Repeat this process when the battery is replaced.

- The battery can be charged on-board (when the battery is installed on the powerchair) or off-board (when the battery is removed).
- To charge while the battery is attached, connect the 3-pin output of the battery charger into the socket on the underside of the controller. To charge while the battery is removed, connect the 3-pin output to the socket on the battery. Connect the outlet plug into a nearby standard wall socket.

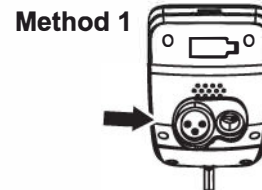

•Ensure the powerchair is switched off and is in 'Electric' mode prior to connecting the charger (see image to right).

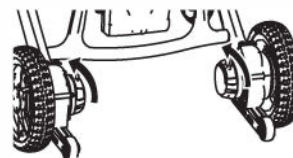

•The LED on the charger will appear blue while charging. When charging is complete, the LED will change to green. It is recommended to charge for 8-12 hours on each charge. After charging is complete, remove the charger from the powerchair/battery and the plug from the wall socket. Store the charger in a safe location.

•If you use your powerchair on a daily basis, charge the batteries as soon as you are finished with the day's activities, and leave it on the charge until you are ready to use the following day.

•If there is a longer period of no use, it is recommended to charge the battery every two months, and use it for more than 20 minutes. This may help preserve /

#### Note:

The charger provided by our company is a **24V/2A** charger, which complies with **IEC 60601-1:2005/AMD2:2020** Medical Electrical Equipment Part 1: General Requirements for Basic Safety and Basic Performance  
Please be sure to use the charger provided by our company to charge the battery. It is prohibited to use other types of chargers for charging.

### 7.4 Overload protector

This component is a safety component of the wheelchair. When the motor is overloaded, it can immediately cut off the power supply to protect the motor and electrical components from damage. To restore the protector function, please contact the customer service center.



### 7.5 Safety belt

To avoid driving accidents, passengers must fasten their safety belts when using the wheelchair. (As shown at right)

Note: A seatbelt extender is available as an optional accessory.

## 8. CHARGING & PREPARING FOR USE

### 8.1 Installation



#### WARNING!

Warning Before preparing the powerchair, ensure these instructions have been read and fully understood. Prepare the powerchair in a dry, indoor environment. Risk of electric shock if prepared in a damp area. Only competent persons are to prepare the powerchair for use. If in doubt, contact your Pride Provider or Pride Mobility Products. Ensure a risk assessment in line with local health and safety policy is undertaken to ensure that staff are not put at risk when performing assembly activities.

### 8.2 Battery Charging



#### WARNING!

- Do not open the battery.
- Do not connect an extension cord to the battery charger.
- Keep metal objects away from the battery terminals; electric shock may occur.
- Ensure the charging cable is not under excessive tension to avoid cable damage -damaged cables can create an electrocution /fire risk.
- Ensure the battery is not exposed to direct sunlight or a secondary heat source -direct heating of the battery via an external source could pose a fire risk or cause an explosion.
- Do not drive the powerchair while the charging cable is attached or connected.
- Only charge the Jazzy Carbon 27 Powerchair with the approved charger. Never charge the Jazzy Carbon 27 Powerchair using a different charger.



#### CAUTION!

Charge fully before each use.

### 8.3 Assembling

Unpack powerchair and stand on its legs so it is standing in an upright folded position . First flip the footrest forward, and then remove the pearl cotton protective pad (**Fig.1**) located above the battery compartment. Next, remove the battery(**Fig.2**) , and then take out the two pearl cotton protective pads inside the battery compartment.

Finally, reinsert the battery into the compartment until you hear a click, indicating it is locked into place. When unfolding the wheelchair, press the backrest with one hand and the seat with the other hand, and pull the wheelchair forward and backward (**Fig.3**). When you hear a click, it indicates that the latch has been stuck into the locking pin (**Fig.4**), and the wheelchair has been unfolded.

Find the plug of the controller and battery connection cable under the seat, align the arrow side of the plug and push it in horizontally. After completion, gently pull the cable to confirm that it is not loose (**Fig.5**) The cable is routed from above the controller and through the rear frame to ensure that it does not become entangled when the wheelchair is folded(**Fig.6**) .

Install joystick by choosing preferred side, then turn the securement knob to loosen and then insert the joystick tubing(**Fig.7**).When the required position is reached, tighten the knob to secure.Connect the 2 terminals ensuring

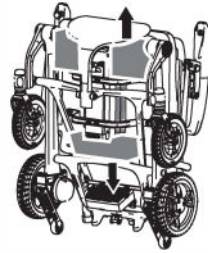

Fig.1

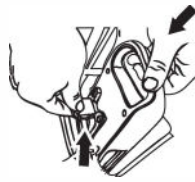

Fig.2



Fig.3

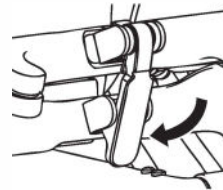

Fig.4

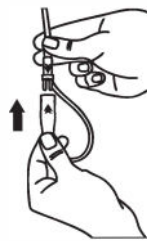

Fig.5

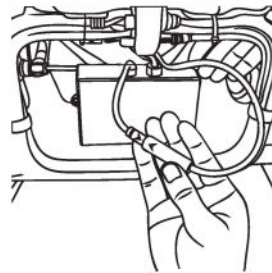

Fig.6



Fig.7



Fig.8

ends are locked in place(**Fig.8**) .Add the cable clips to the side of the frame and press the long cable into the clip.(**Fig.9**)

### Folding

If the wheelchair needs to be folded, please pull up the latch at the rear of the wheelchair body(**Fig.10**), meanwhile flip up the seat cushion, then the wheelchair could be folded. With the wheelchair body folded in place, flip up the footrest.

### 8.4 Checking Before Use

It is important to check the functionality of the powerchair before the initial use to ensure its safe operation:

- With the motor freewheel levers set to manual, the powerchair should move freely when pushed by hand. With both freewheel levers set to electric, it should not be possible to move the powerchair by hand(**Fig.11**).

- Switch the powerchair on, ensuring the joystick is released.

- Wait for two seconds after start up, and then gently press the joystick in any direction. The battery indication light should be on.

- Rotate the joystick in all directions and ensure the front wheels rotate freely.

- Release the joystick after moving in any direction. The joystick should

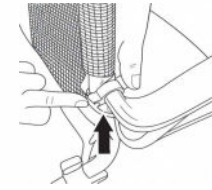

Fig.9

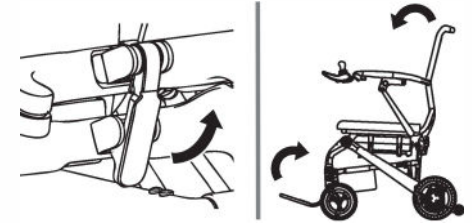

Fig.10

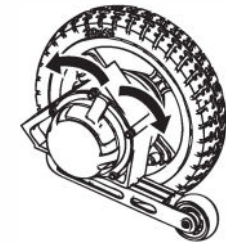

Fig.11

immediately return to the middle position and the powerchair should stop.

**8.4.1** Press the horn button to determine whether the horn makes a sound.

**8.4.2** Turn the joystick to the front and observe the wheelchair wheels turning, then turn it in the remaining direction to observe whether the wheels turn.

**8.4.3** Release the joystick, it will immediately return to the middle position, and the wheels should stop turning.

**8.4.4** Press the power switch lightly, the battery and speed indicators will light up, and press the "-" key to adjust the speed to 1 level. Speed requirements for each gear(Fig.12):

GEAR	km/h(±0.5)	mph(±0.3)
5	6	3.7
4	5	3.1
3	4	2.5
2	3	1.9
1	2	1.2



Fig.12

**Turn the joystick forward to confirm that the wheelchair can move forward normally.**

**Release the joystick, and the joystick will immediately return to the middle position, confirming that the wheelchair stops immediately.**

#### 8.4.5 Battery Removal(Fig.13)

1. Press the bottom latch of the battery.
2. Pull the battery handle outward simultaneously to remove the battery.

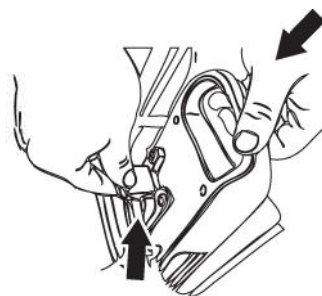

Fig.13

#### Battery installation:

1. Align the bottom guide rail of the battery with the battery compartment guide rail.
2. Push the battery in smoothly until you hear a click, indicating it is locked into place.

Before using the electric wheelchair for the first time, be sure to check its functions to ensure safe operation:

#### Electric mode test

1. When the wheelchair needs to be driven (whether electric or manual), the brake lever must be pushed down to disengage the lever from the tire.
  2. Press the "switch" button on the battery box to either end to connect the wheelchair to the power supply.
  3. Press the power button of the controller to start the electric wheelchair and make sure the direction keys are released. Wait for the controller screen to light up and test that the control direction of the controller joystick corresponds to the direction of the electric wheelchair.
  4. Gently press the horn button and the controller buzzer will sound.
  5. Gently press the "+" or "-" key, and the unit digits on the controller screen will increase and decrease accordingly.
- After completing any of the above movement operations, turn the joystick and immediately return it to the middle position. The electric wheelchair should stop running.

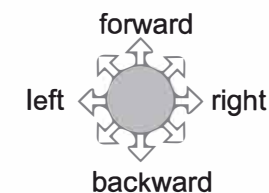
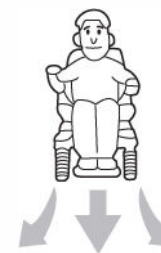

## 9. OPERATION OF THE POWERCHAIR

### 9.1 Driving the Powerchair

You must exercise awareness, caution, care, and common sense when operating your powerchair. Always keep in mind your own limitations and substance use.

Users may encounter difficult manoeuvring situations such as narrow doorways, traveling up and down ramps, cornering, and travelling on uneven terrain. Be sure to lower the speed, take your time, and carefully manoeuvre the powerchair. For your safety, fasten the safety belt before you drive the powerchair.



#### WARNING!

- Never use your powerchair while tired, smoking, under the influence of alcohol or other mind-altering substances. Be aware of precautions, warnings, and safety issues when taking prescribed or over-the-counter drugs before driving. If there is a history of active seizures in the last 6 months, clearance should be obtained from a neurologist that the patient's seizures do not prohibit safe use of a motorised device.
- When operating the powerchair, the occupant is expected to be positioned appropriately in the seat, with their feet inboard of the footplate at all times, and limbs clear of moving parts to prevent entrapment. Never reach, lean or bend when driving the powerchair.
- Always make sure the power is off, with the powerchair and backrest fully unfolded before getting on /off the powerchair. Carers should keep clear once the powerchair is powered on. Do not operate the controls while anyone is entering or leaving the powerchair - a hazard may be introduced. Do not let children play near or operate the powerchair. Keep your feet on the foot board at all times during operation. Do not stand on the foot board.
- Keep your hands and feet away from moving parts while driving. Be aware of loose-fitting clothes that can become caught in the drive wheels.
- Always reduce your speed and maintain a stable centre of gravity when turning corners. Caution Always check the Powerchair is free of obstructions before use.

### 9.2 Steps, curbs & Fixed Obstacles

Use extreme caution when operating your powerchair near curbs, porches, stairs, escalators, drop-offs, unprotected ledges, and raised areas. Approach slowly, and make sure the front of the powerchair is perpendicular to the obstacle.

•**To manoeuvre up a fixed obstacle:** Increase the forward speed until the powerchair has cleared the obstacle, and then you may reduce the speed or return the joystick to neutral.

•**To manoeuvre down a fixed obstacle:** Reduce the forward speed just before the front wheels come in contact with the obstacle and remain at the reduced speed until powerchair has cleared the obstacle, then you may increase the forward speed.

•**Correct Approach:** Perpendicular to the curb.

•**Incorrect Approach:** Angled or reverse approach.

**Correct Approach:**

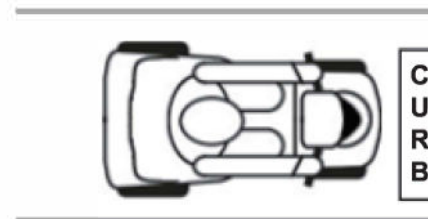

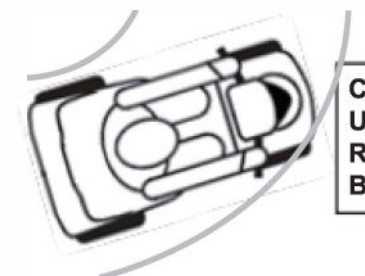

**Incorrect Approach:**



#### WARNING!

Never attempt to navigate your powerchair over a curb or other fixed obstacle taller than the maximum ground clearance. Never attempt to navigate your powerchair backwards over an obstacle. Make sure that there are no steps, curbs or other obstacles behind you while reversing - tipping / falling risk. Never attempt to operate your powerchair on steps or escalators.

### 9.3 Engineering menu operation instructions

The controller is turned on and the instrument display is normal. Press and hold the  and  buttons for about 3 seconds. After the controller emits 2 beeps, release the combination button to enter the engineering interface, as shown in Figure 1 (engineering interface 1) and Figure 2 (engineering interface 2):

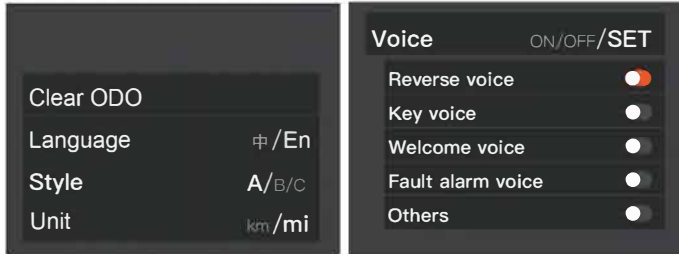

**Figure 1 (Project interface 1) Figure 2 (Project interface 2)**

**Note:** The contents that can be set in the engineering interface include: language switch, A/B/C theme interface switch, speed unit switch, sound switch (including back-up sound, key sound, startup sound, fault sound, and others)

#### Operation steps, for example:

Theme interface switching: After entering the theme interface, press the "-" key to select the previous item, press the "+" key to select the next item, press Horn to switch the theme, press the power switch to confirm, the system automatically saves the settings and exits the engineering interface, and automatically returns to the most recently selected theme interface, as shown below (other settings are operated in the same way).



Three theme interfaces can be switched at will (each style main interface page displays the following five types of information)

1. Real-time speed
2. Total mileage
3. Speed level
4. Power meter
5. Headlight switch indicator light

### 9.4 Wheelchair Lock/Unlock Function (Child Lock Feature)

#### (1) Locking

With the power on:

- Press and hold the "Power switch" button for more than 3 seconds.
- While holding the power button, push the joystick forward and then backward.
- A "beep beep" sound is heard followed by a repeating "beep... beep..." indicating the wheelchair is locked.

During lock state:

Only the "Power switch" button remains functional. All other buttons and joystick control are disabled.

After 10 alert beeps, the controller automatically shuts down. Upon reboot, the wheelchair remains locked.

#### (2) Unlocking

With the power on:

- Press and hold the "Power switch" button for more than 3 seconds.
- While holding the power button, push the joystick forward and then backward.
- A single "beep" confirms the wheelchair is unlocked, and all functions are restored.



#### CAUTION!

Make sure the powerchair functions work correctly before operating, using the checklist in section 8.4 for guidance.



#### WARNING!

If your powerchair moves accidentally, immediately release the joystick to stop movement.

## 9.5 Inclines

Use caution when approaching inclines or declines. If necessary, lower the speed before travelling on a slope. When travelling up an incline, try to keep the powerchair moving forward. If you must come to a stop, use caution and slowly accelerate the powerchair forward. When travelling down an incline, lower the speed on your powerchair to the slowest setting, and proceed cautiously. If the powerchair is travelling down the incline faster than you expected, slowly return the joystick to the centre to come to a stop, then slightly push the joystick forward again to continue safely down the incline.



### WARNING!

Drive your powerchair straight up or down an incline, never backwards. Erratic movements, or back and forth patterns may increase the chance of tipping. Be careful when driving on inclines. Inclines vary and doing so may decrease stability. Do not, under any circumstances, travel on a slope greater than the maximum stability angle for this powerchair.

## 9.6 Antitipper instruction

The anti-tip wheels are a safety device that can help to prevent the powerchair turning over when attempting to traverse too steep an incline.

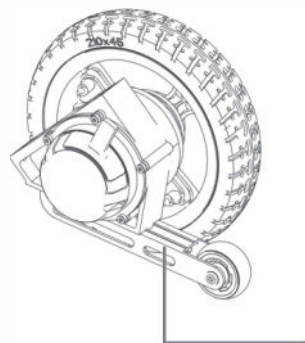

Anti-tip Wheel Device

## 9.7 Precautions for safe use

If you need to use your powerchair outdoors, please ensure that the weather conditions are good. Check the weather before and during your journey. Do not use in inclement weather such as heavy rain or snow. If you find yourself caught in inclement weather whilst operating your powerchair, proceed to the closest shelter immediately and turn off the power. Completely dry your powerchair before operating, charging, or storing it.

### Note:

Before each use, please check whether the anti-tipping structure is intact. If there is any abnormality, please contact the Supplier.



### WARNING!

Do not take your powerchair on roads or highways.

Be cautious when driving your powerchair in busy areas, such as shopping malls.

If you get caught outside in the rain, seek shelter immediately and dry the powerchair with a cloth.

Do not drive your powerchair at night without proper lighting. Avoid exposure to moisture, standing water, rain, snow, ice or salt when possible. Operating in rain, snow, salt, mist and on icy or slippery surfaces may have an adverse effect on the electrical system.

At extreme temperatures, the batteries may freeze, and your powerchair may not be able to operate. In extreme high temperatures, it may operate at slower speeds due to a safety feature of the controller that prevents damage to the motors and other electrical components. Operational limits stated in section 9.1 must be observed.



### CAUTION!

If you are unsure of a surface, such as gravel, it is recommended to avoid it and locate an alternative route.

## 9.8 After Use Instructions

Turn off the power after use of the powerchair. Store the powerchair in a location that cannot be interfered with by children, meets the storage temperatures listed in section 5 and is free from excess moisture.

Clean the powerchair with a soft cloth and ensure it is dry (see section 10). Do not use chemicals to clean the powerchair. If the seat cover requires cleaning, remove it to be washed and allow to dry before placing back on the powerchair. If the powerchair is to be stored for a long period of time, we recommend fully charging and then removing the battery to prevent battery drain.

## 10. CLEANING



### WARNING!

Never use direct contact with water to clean the powerchair. This could cause damage to the electrical components and put the user at risk. Only a damp cloth should be used. Always disconnect the Jazzy Carbon 27 Powerchair from the mains supply prior to cleaning. Never use any neat bleach or similar chemicals on the seat or armrests, as this may cause the seat to dry out and crack. PPE must be worn during manual decontamination to prevent the risk of infection. Deviating from the specified cleaning instructions could cause a biological hazard, especially in multi-user environments, and adversely affect the life and efficiency of the product.



### CAUTION!

Regular cleaning can help prolong the lifespan of the powerchair. The surface of the powerchair frame has been treated with a protective coating to allow for easy removal of dirt. Use a damp cloth with a mild soap to clean the frame and then dry thoroughly.

## 11. MAINTENANCE & SERVICING



### WARNING!

Always disconnect the powerchair from the main power supply and remove the battery prior to performing any maintenance procedures (where viable). Never attempt to deconstruct the enclosures, re-wire any components or replace internal battery components. Modification of the powerchair is not allowed without the permission of the manufacturer and electrical system components are only to be replaced by service technician. Please contact your Pride Provider or Pride Mobility Products. for the service technician nearest to you. No maintenance or servicing should be conducted while the device is in use - risk of electric shock, entrapment, loose parts, etc. If not possible due to the occupant's mobility, a risk assessment should be carried out, and if deemed safe to proceed, care should be taken to avoid contact with the occupant when working on electrical items. Failure to carry out the following checks at the stated frequencies could negatively influence the essential performance of the powerchair and as a result put individuals at risk. Allow all components to cool before performing maintenance. Parts of the motor system can generate heat while driving.



### CAUTION!

All maintenance should be conducted by a competent person. Disassembling the controller, motor, or charger by anyone other than an approved technician is prohibited and voids any applicable warranty. For any maintenance concerns, contact your Pride Provider or Pride Mobility Products.

### 11.1 General Guidelines









Routine maintenance is required to ensure the maximum use of your powerchair. While some of the maintenance can be done by yourself, you may need assistance from an authorised service engineer. If you have any doubts, contact your Pride Provider or Pride Mobility Products. If there are any signs of damage, or the powerchair is not performing as it should, withdraw it from service until the powerchair has been repaired and is fit for use.

Preventative maintenance is key to keeping the Powerchair in prime operating condition. Follow the Maintenance Schedule at the end of this manual to periodically inspect the Powerchair for serviceable items.

- Avoid abuse to the joystick and control functions.
  - Avoid prolonged exposure to extreme heat or cold
  - Keep the powerchair clean and free from moisture.
  - Never use a conditioner on the tread of the wheels.
  - If only displays 1 grid of power appear on the battery gauge, the batteries are nearly out of charge and should be recharged as soon as possible.
  - Check for the presence of flat spots on the tyres.
  - Check all cable connections, ensuring they are fastened and not corroded.
  - Check the frame and all components for loose fasteners and tighten where
- The following conditions may indicate a serious problem with your powerchair. Contact your Pride Provider or Pride Mobility Products. if one of the following
- Motor or gearbox noise
  - Frayed electrical harnesses
  - Cracked or broken connections
  - Uneven wear on the tyres
  - Veering to one side when steering straight
  - Bent or broken wheel assemblies
  - Will not power on
  - Loose seat or seat components
- If in doubt about the correct replacement of a component, contact your Pride Provider or Pride Mobility Products.

## 11.2 Fault Detection

For your convenience, the wheelchair is equipped with an automatic fault warning system. In the event of a malfunction, an alarm will sound and corresponding fault codes will be displayed on the LCD screen. Use the table below to identify and troubleshoot issues.

Fault Analysis		Solution
Controller Internal Fault		Return to factory service
Joystick Fault		Return to factory service
Right Motor Fault		<ol style="list-style-type: none"> <li>1. Check if the right motor connector is defective or the wire is disconnected.</li> <li>2. Check and troubleshoot for right motor faults.</li> </ol>
Right Motor Hall Fault		<ol style="list-style-type: none"> <li>1. Check if the right motor connector is defective or the wire is disconnected.</li> <li>2. Check and troubleshoot for right motor hall faults.</li> </ol>
Right Brake Fault		<ol style="list-style-type: none"> <li>1. Check if the right motor connector is defective or the wire is disconnected.</li> <li>2. Check and troubleshoot for right brake faults.</li> </ol>
Left Motor Fault		<ol style="list-style-type: none"> <li>1. Check if the left motor connector is defective or the wire is disconnected.</li> <li>2. Check and troubleshoot for left motor faults.</li> </ol>
Left Motor Hall Fault		<ol style="list-style-type: none"> <li>1. Check if the left motor connector is defective or the wire is disconnected.</li> <li>2. Check and troubleshoot for left motor hall</li> </ol>
Left Brake Fault		<ol style="list-style-type: none"> <li>1. Check if the left motor connector is defective or the wire is disconnected.</li> <li>2. Check and troubleshoot for left brake faults.</li> </ol>
Battery Fault		<ol style="list-style-type: none"> <li>1. Check if the battery connector is defective or the wire is disconnected.</li> <li>2. Check and troubleshoot for battery faults.</li> </ol>

### 11.2.1 Repair

This wheelchair is equipped with three theme interfaces. The display styles vary across different themes, but the content shown is consistent with the fault display interface. This manual uses Fault Interface A for demonstration purposes. Users of other interfaces may refer to the corresponding relationships for operation. Contact your provider to discuss the replacement of components on the powerchair. Some spare parts may be replaced by the user under instruction from service personnel, however other components will require installation by a service engineer.

## 12. DISPOSAL OF PARTS

When the powerchair, the electrical system or any associated packaging and accessories have come to the end of their useful life, follow W.E.E.E. (Waste Electrical and Electronic Equipment) policies, local and national regulations for recycling and disposal.

Individual parts can be separated and disposed according to the type of material. The electrical components of the powerchair should not be disposed in municipal waste. Some of these electrical components could be harmful to the environment and where viable, can be recovered and reused / recycled.

When the powerchair is unpacked for the first time, the cardboard box, and plastic packaging used can be recycled at recycling centres that offer suitable cardboard and polymer recycling programmes respectively.

For further information about disposal, contact your local waste agency, recycling centre, or provider. Please contact your Pride Provider or Pride Mobility Products for further information and instruction.



### **WARNING!**

The Powerchair and any associated parts are to be decontaminated before disposal to avoid the risk of cross contamination.

### 13. ELECTROMAGNETIC COMPATIBILITY (EMC)

Electromagnetic interference (EMI) tests have shown to produce adverse effects on the performance and control of electrically powered mobility devices. EMI can be produced from different sources, such as cellular phones, amateur radio transmitters (HAM), microwave signals and emergency vehicle transceivers. The EMI produced from hand-held radios are of special concern.

The EMI waves can cause unintentional movement of the powerchair, or damage to the controller. Every electrically powered mobility device has a resistance to EMI. The higher the resistance level the greater the protection. The intensity of the interference can be measured in volts per meter, V/m.

If the powerchair or any alternative equipment is found to be operating abnormally, turn off the piece of equipment that is believed to be causing the interference (if possible, as soon as it is safe) to identify the source of the RF energy. Once identified, mitigation measures are to be taken, such as the separation distances being increased and / or the device(s) being re-orientated. If the powerchair continues to operate abnormally, turn off at the mains supply and contact your Pride Provider or Pride Mobility Products.

The warnings listed below are recommended to prevent possible interference with the control system of your powerchair. Your powerchair, with no modifications, has an immunity level of 20 V/m. For specific emissions and immunity information relating to the powerchair, contact your Pride Provider or Pride Mobility Products. Report EMI incidents to Pride Mobility Products using the details provided in section 2.



**WARNING!**

- Do not operate hand-held transceivers or turn on personal communication devices while the powerchair is powered on. Avoid use adjacent to or stacked with other equipment where possible. If adjacent use is necessary, the powerchair should be observed to verify normal electrical operation in the configuration in which it is to be used.
  
- Use of accessories and cables other than those specified or provided by Pride Mobility Products. could result in increased electromagnetic emissions or decreased electromagnetic immunity of the powerchair and result in improper operation or driving performance.
  
- Portable RF communications should be used no closer than 30 cm to any part of the powerchair(including its cables), otherwise a degradation in performance could result.

Avoid use around radio transmission systems, such as radio or television stations.

### 14. SPECIFICATION

<b>Product name</b>	Powerchair
<b>Model Number</b>	Jazzy Carbon 27
<b>Top Speed*</b>	3.7 mph (6 kph)
<b>Maximum Range*</b>	9.3 miles (15 km)
<b>Rated Slope</b>	9°
<b>Maximum Stability Angle</b>	9° (static) 6° (dynamic)
<b>The distance between the feet and the ground</b>	3" (75 mm)
<b>Obstacle Clearance</b>	0.984" (25 mm)
<b>Minimum Turning Radius</b>	33.4" (850 mm)
<b>Unfolded (L×W×H)</b>	890×595×930 mm
<b>Folded (L×W×H)</b>	700×595×340 mm
<b>Seat Height</b>	19.09" (485 mm)
<b>Seat Width×Depth</b>	17.3" (440 mm) ×16.54" (420 mm)
<b>Armrest Height</b>	9.25" (235 mm) from front edge of seat
<b>Backrest Height</b>	19.29" (490 mm)
<b>Front Wheels</b>	6.89"×1.3" (175×33 mm)
<b>Rear Wheels</b>	8.27"×1.77" (210×45 mm)
<b>Anti-Tip Wheels</b>	2"×0.787" (50×20 mm)
<b>Wheel Type</b>	Solid, PU
<b>Maximum Occupant Mass</b>	300lb (136 kg)
<b>Product weight</b>	27.78 lb (12.6 kg) excluding battery
<b>Battery weight</b>	4.63 lb (2.1 kg)
<b>Motor Type</b>	24V/250W
<b>Battery Supplied</b>	24 V, 12 Ah, Lithium
<b>Max Controller Output</b>	35 A
<b>Max Charger Output</b>	2 A
<b>Application environment</b>	See section 3.1
<b>Liquid ingress protection</b>	IPX4 - Protection from water splashes

The driving distance is based on a 100 kg user weight and will be reduced if used frequently on slopes, rough ground or to climb curbs. Speed and range may also vary depending upon user weight, battery charge and condition, incline, weather conditions and driving behaviour.

## 15. MAINTENANCE SCHEDULE

INSPECTION	AT ANY TIME	WEEKLY	MONTHLY	SIX MONTHLY
Joystick returns to centre when released and is free from damage	√	√		
Exposed electrical cables have not been damaged	√	√		
Check tyres are in good condition and free from flat spots	√	√		
Seat, armrests and footrests have not experienced damage.	√	√		
Batteries (and surrounding area) are free from corrosion			√	
Electrical junction to control unit is secure			√	
Check brake functionality by pressing the joystick in any direction and releasing. The joystick should return to centre and the powerchair should immediately slow down.			√	
Check the tyres have sufficient tread				√
Check the full rotation of the front castors and ensure they align with the rear wheels when driving straight				√
Check all fasteners are tight and all components are secure.				√
Ensure the powerchair is clean of dirt and built-up residue				√

SUGGESTION-Once a year, take your powerchair to an authorized Pride Provider for inspection and maintenance.

## 16.OPENING AND CHECKING

Open the packing box, and you can check whether there is anything missed or damaged.Packing List

NO.	Produce Name	Quantity	Remark
1	Power Wheelchair	1 PC	
2	Charger	1 PC	
3	Instruction manual	1 PC	
4	Controller	1 SET	
5	Warranty card	1 PC	

## 17. WARRANTY

### 17.1 Warranty

#### 17.1.1 5 Years warranty on frame

17.1.2 Within 1 year from the purchase date, for the following parts, we will supply free maintenance and replace service for original customer after the dealer check there are materials and production defect.

- **Electrical control or lever system**
- **Motor/Drive System**
- **Bearing and shaft sleeve**
- **Battery**

Please note the warranty service is provided by your dealer, and finally finished by our after-sales department and dealer together.

Out of warranty

- **ABS plastic cover shell and rubber pad**
- **Tyre**
- **Interior decoration&cushion**
- **Damage by abuse, wrong operation, accidents and negligence**
- **Damage by wrong maintenance and storage**
- **Business use or other abnormal use**



USA  
Pride Mobility Products corp.  
401 York Ave Duryea ,PA 18642

Canada  
Pride Mobility Products corp.  
5096 South Service Road  
Beamsville, Ontario L0R 1B3

Australia  
Pride Mobility Products Australia Pty. Ltd.  
20-24 Apollo Drive  
Hallam, Victoria 3803  
www.pridemobility.com.au

New Zealand  
Pride Mobility Products New Zealand Ltd.  
38 Lansford Crescent  
Avondale  
Auckland, New Zealand 1007  
www.pridemobility.co.nz

UK  
Pride Mobility Products Ltd.  
32 Wedgwood Road  
Bicester, Oxfordshire OX26  
4UL www.pride-mobility.co.uk

Germany  
Pride Mobility Products GmbH  
GmbH Josef-Förster-Straße  
6-833161 Hövelhof  
Germany

UK Responsible Person  
SUNGO Certification  
Company Limited  
3rd floor.70 Gracechurch  
Street, London. EC3V 0HR

The Netherlands  
Pride Mobility Products Europe BV  
De Zwaan 3  
1601 MS Enkhuizen  
Netherlands  
www.pride-mobility.nl

Italy  
Pride Mobility Products Italia S.r.l.  
Via della Technicas, 3  
Loc. Prato della Corte  
00065-Fiano Romano (RM)  
www.pride-italia.it

France  
Pride Mobility Products SARL  
26 rue Monseigneur Ancel  
69 800 Saint-Priest  
www.pridemobility.fr

Spain  
Pride Mobility Products Spain SLU  
Calle Velazquez 80 6D  
28001 Madrid  
www.pridemobility.com

UK Responsible Person  
Sungo Europe BV  
Fascinatio Boulevard 522,  
Unit 1.7.2909VA  
capelle aan den IJssel,  
The Netherlands

Serial number:

